



SOCIETY OF COMPOSERS, Inc.

...dedicated to the promotion, composition, performance, understanding and dissemination of new and contemporary music...

NEWSLETTER CONTENTS

XXXVIII : 1, January-February 2008

Resources

Learn about the Newsletter, upcoming SCI Events, and our many online resources



Page 2

About SCI



Message from the President, members of the National Council/ Executive Committee

Page 3

Feature

Review of the 2008 National Conference in Atlanta, Georgia, by Luke Gullickson



Page 4

SCItings



Performances, Awards, Commissions, Honors, Publications, and other Member Activities

Page 7

Tech Corner

New column devoted to tech how-to questions written by editor Anthony Cornicello

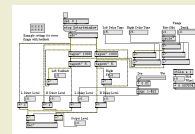

Page 9

Join SCI



SCI is an organization for composers. Our membership categories include full member, student member, retired member, or life member.

Page 10

ANACRUSIS...

Meet the New Editors of the SCI Newsletter



*Anthony Cornicello
Editor, SCI Newsletter
Professor, Eastern Connecticut State University*



*Benjamin Williams
Editor, SCI Newsletter
DMA Student, Ohio State University*

ANTHONY CORNICELLO:

Composer **Anthony Cornicello** (b. 1964) writes music that blurs distinctions between performers and electronics, timbre and harmony, composition and improvisation, and explores the boundaries of what may be considered post-classical concert music. His music is vibrant and visceral, full of rhythmic energy and harmonic sophistication, and his forays into live electronics have led to exciting combinations of instruments and processed sound. He has been commissioned to write music for the Scorchio Electric String Quartet, ModernWorks! (funding from Meet the Composer/ Commissioning Music USA), the New York New Music Ensemble, the Group for Contemporary Music, and the InterEnsemble of Padova, Italy. His music has been presented as part of the Darmstadt and June in Buffalo Festivals. Cornicello's works are published by C.F. Peters and his music appears on the Centaur and Albany labels. Anthony directs the Electronic Music lab at Eastern Connecticut State University, where he is an Associate Professor.

BENJAMIN WILLIAMS:

Benjamin Williams is currently pursuing a Doctor of Musical Arts degree at The Ohio State University. He received his Master of Music degree in composition from the University of Akron. His composition teachers include Daniel McCarthy, Nikola Resanovic, and Tom Wells. His music has been performed across the United States by a wide variety of performers and ensembles. His music has been performed at two SCI National Conferences (including 2008), The Electronic Music Midwest Festival, Kentucky New Music Festival, The University of Nebraska New Music Festival, SCI Region VI Conference, and the Akron New Music Festival. Williams has also won the ASCAP/ Victor Herbert Award as well as the APSU Young Composers Competition.



...dedicated to the promotion, composition, performance, understanding and dissemination of new and contemporary music...

NEWSLETTER CONTENT:

Resources	Contribute	About	Feature	Activities	Join SCI
Gain access to the Newsletter's archive, including all past issues, and our new online archive.	Proposals for editorial members of the National Council and Executive Committee.	Profile of the 2008 Region VI Conference, by Scott Brinkman.	Reaction of the 2008 Region VI Conference, by Scott Brinkman.	Professors, artists, composers, tutors, publications, and other accomplishments.	SCI is an organization for composers. Our leadership programs include full members, student members, and members at large members.
Page 2	Page 2	Page 3	Page 4	Page 6	Page 8

MEET THE NEW ASSISTANT EDITOR FOR THE SCI NEWSLETTER

Meet the Editor (in relation to new departures) in the assistant editor of the newsletter. For more information, contact the editor at editor@sci.org. The editor of the newsletter is currently **Benjamin Williams**. The composition deadline for the newsletter is **January 15, 2009**. The composition deadline for the newsletter is **January 15, 2009**. The composition deadline for the newsletter is **January 15, 2009**.



About the Newsletter

Editors: Anthony Cornicello
Benjamin Williams

Circulation: 1400

Access: available on the SCI website at

<http://www.societyofcomposers.org/data/publications/newsletter/current.pdf>

Frequency of Publication: bimonthly

Newsletter Contact Information:

Anthony Cornicello
Eastern Connecticut State University
Shafer Hall, Room 109
83 Windham St
Willimantic, CT 06226
(860) 236-3892
cornicello@sbcbglobal.net

Benjamin Williams
504 Hemston Ct
Gahanna, OH 43230
(330) 268-2590

benjamin@williamscomposer.com

For other SCI business:

Society of Composers, Inc.
P.O. Box 687
Mineral Wells, TX 76067-0697
secretary@societyofcomposers.org

Copyright © 2008

Society of Composers, Inc.

All rights reserved.

How to Submit Items to the Newsletter

Articles: The Newsletter welcomes submissions of articles to run in future issues. Articles, if accepted, may be edited for length and content. Please include a photo with all submissions if possible (photo may be of author).

Member News + Photos: Please send all member news and activities with a photo. Submitted items may be edited.

Ideas/Suggestions: The Editors welcome any other ideas or suggestions.

Submit to the newsletter via email at newsletter@societyofcomposers.org

Upcoming SCI Events

Spring 2008 (April 16-19)
2008 Region VI Conference

Sam Houston State University
Huntsville, TX

Host: Trent Hanna [trenthanna@hotmail.com]

Submission deadline: Past

Spring 2009 (dates TBA)
2009 Region VI Conference

The Bass School of Music at
Oklahoma City University
Oklahoma City, OK

Host: Edward Knight [eknight@okcu.edu]

Submission deadline: TBA

Spring 2010 (dates TBA)
2010 Region VI Conference

Kansas State University
Manhattan, KS

Host: Craig Weston [cweston@ksu.edu]

Submission deadline: TBA

Fall 2008 (October 10-11)
2008 National Student Conference

Ball State University
Muncie, IN

Submission deadline: TBA

See our website at

<http://www.societyofcomposers.org/>
for more details.

Internet & Email

www.societyofcomposers.org

The SCI website is an up-to-date source of information:

- Conference dates and submission guidelines
- Contact information and links to member webpages
- Student chapters and opportunities
- CDs and journals produced by SCI
- Details on SCI such as membership options, listings and contacts for officers, regional structure, by-laws, newsletter archives, and more...

SCION

SCION is a listing of opportunities on our website exclusively for members. It is updated on a continual basis so that it may be checked at any time for the most current notices. In addition, members are emailed on the first Monday of each month to remind them to visit the site for new or recent postings. The large number of listings is easily managed by a table of contents with links to the individual notices. In-depth coverage--contest listings in full--all items listed until expiration-- this is a valuable resource that you may print in its entirety or in part at any time.

John Bilotta, SCION Editor
scion@societyofcomposers.org

[scimembers]

scimembers is a member-driven e-mail mailing list that is intended to facilitate communication between members of the Society on topics of concern to composers of contemporary concert music. It conveys whatever notices or messages are sent by its members, including announcements of performances and professional opportunities, as well as discussions on a wide variety of topics. For more information, including how to join and participate in the listserv:

<http://www.societyofcomposers.org/data/publications/listserv/listserv.html>

NATIONAL COUNCIL

President

Thomas Wells
Ohio State University

Region 1

Scott Brickman
University of Maine at Fort Kent

Beth Wiemann
University of Maine

Region 2

Anneliese Weibel
SUNY-Stony Brook

Daniel Weymouth
SUNY-Stony Brook

Region 3

Harvey Stokes
Hampton University

Bruno Amato
Peabody Conservatory

Region 4

Mark Engebretson
University of North Carolina at Greensboro

Paul Osterfield
Middle Tennessee State University

Region 5

Mark Phillips
Ohio University

Frank Felice
Butler University

Region 6

Eric Honour
University of Central Missouri

Ken Metz
The University of the Incarnate Word

Region 7

Bruce Reiprich
Northern Arizona State University

Glenn Hackbarth
Arizona State University

Region 8

Charles Argersinger
Washington State University

Patrick Williams
University of Montana

National Conference Host

Steve Paxton
Sante Fe, New Mexico

Student Conference

Ball State University

President Emeritus

Greg Steinke

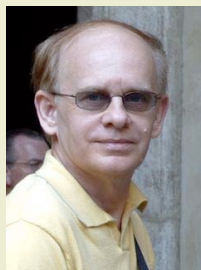

Message from The President

The resumption of our Newsletter is a happy event for SCI. On behalf of Executive Committee

Chair, Jim Sain, I'm happy to announce that Anthony Cornicello of Eastern Connecticut State University, and Ben Williams from The Ohio State University have agreed to serve as co-editors for this publication. The Newsletter is a showcase for member activities, and I'd like to urge all of our members to share their recent accomplishments, including photographs, with our colleagues in SCI through this publication. I also want to enjoin members to contribute special features, such as interviews, polemics, and reviews to the mix.

The Atlanta conference was a big success, thanks to the Herculean efforts of Nick Demos and the excellent performance resources of Georgia State University and musicians from the Atlanta area. The review in this issue will provide more details of this outstanding event.

I would also like to direct your attention to the recently-posted ASUC/SCI record series at societyofcomposers.org. This collection spans roughly thirty years and includes over 40 works in all kinds of genres. I digitized the collection about a year ago and put the project on the back burner until just before the Atlanta Conference. I am impressed with how kindly time has treated most of the works in this collection, and what a variety of styles the series encompassed. The series itself is a tribute to the hard work Richard Brooks has contributed and continues to contribute to SCI.

On another note, our new refereed webzine journal, iSCI, is in preparation for its premiere issue in late Spring. Kudos to the co-editors, Craig Weston and Jason Bahr, as well as the editorial board: John White, Elliott Schwartz, Robert Rollin, and Stephen Heinemann.

Tom Wells
President, SCI

EXECUTIVE COMMITTEE

Chairman

James Paul Sain
University of Florida

Editor, Newsletter

Anthony Cornicello
Eastern Connecticut State University

Benjamin Williams
The Ohio State University

Editor, SCION

John G. Bilotta

Editor, Journal of Music Scores

Bruce J. Taub

Producer, CD Series

Richard Brooks
Capstone Records

Manager, Audio Streaming Project

Thomas Wells
The Ohio State University

Coordinator, Submissions

Lee Hartman
University of Delaware

Representative, Independent Composer

Anne Kilstofte
Phoenix Arizona

Representative, Student Chapters

Nickitas Demos
Georgia State University

Representative, Students

Alexander Sigman
Amsterdam, The Netherlands

Coordinator, SCI/ASCAP Student Competition and Grants

Kari Juusela
Berklee College

Webmaster

Mike McFerron
Lewis University

Web Content Manager

Matthew McCabe
University of Florida

Chair Emeritus

William Ryan
Grand Valley State University

National Conference

A review of the 2008
SCI National Conference
at Georgia State University

By **Luke Gullickson**
MM, University of Texas at Austin

So...pluralism. I know, I know. It's getting to be a tired cliché. But I had to say it right away, because at the moment it's the best explanation I have for what, exactly, composers are up to these days. Whether we like it or not, from time to time we must assess this question, ask ourselves what we're writing and why, look around and try to pin down some movements and trends. I had the fantastic opportunity last month to encounter these issues firsthand at the SCI National Conference, held February 20-23 at Georgia State University in Atlanta.

The week got off to a strong start Wednesday night with a concert by GSU's neoPhonia New Music Ensemble, under the direction of Nickitas Demos. The student performers put forth admirable effort in assembling these varied works. The Piedmont Winds presented the conference's first piece by guest composer George Tsontakis, *Birdwind*, which demonstrated the composer's skillful instrumental writing. The most energy, however, was present in the following piece, Ed Martin's *Psychoetic*, which sent us all out to the reception charged up and ready for the week.

The Thursday morning session included performances organized by the composers, and as throughout the week, it was a joy to see so many wonderful performers engaged with new music and willing to travel in order to perform it. This first concert was highlighted by Clifton Callender's *Point and Line to Plane*, a striking, colorful piece executed with a superb sense of touch and attack by pianist Hui-Ting Yang.

That morning also held a panel discussion on the subject of Music Journalism in the 21st Century, featuring *Creative Loafing's* Mark Gresham, Darren Nelsen of the Atlanta Composers Blog, and Pierre Ruhe, classical music critic for the *Atlanta Journal-Constitution*. The conversation began with ruminations on the past and future of journalism and the falling influence of print media, and eventually gave way to a spirited debate on the more general roles of the composer and of the critic. If there hadn't been another concert to get to, we might have gone on all day.

Luckily, though, we made it back for a full recital by pianist Jeri-Mae Astolfi, who tackled an enormous program of extreme variety. There was a great deal of piano music on the conference, and this program illustrated the multiplicity of approaches to and influences on the medium. Laurence Sherr's *Nocturne* was a fetching tribute to Debussy; Brian Belet's *Drei Kinderstucke* capably expressed the aphoristic style of Webern;



top: Matthew McCabe and Stefanie Acevedo
middle: Michael Solomon, Chester Udell, and Kyle Vegter
bottom: Dr. James Paul Sain

Alan Beeler's *4 Little Bi-Scalar Pieces* recalled Hindemith in its quartal harmony and contrapuntal approach; and Trent Hanna's *A Piece of Snow* utilized a standard place-based program while also incorporating improvisatory touches.

Thursday afternoon's concert consisted of electroacoustic works, and not surprisingly, it was among the more diverse programs on the conference. Anthony Cornicello demonstrated his inventive glove that controlled sound elements in the appropriately named *The Gloved One*. Two works, Per Bloland's *Graveshift* and Orlando Legname's *Agua de Pingo*, included video. Benjamin Williams' *Mirrored Pursuit* for live piano and tape blended techno beats with Latin jazz. And there were also two traditional works for electronic playback, Neil Flory's *Four Variants* and James Paul Sain's *Beondegi*.

On Thursday night the GSU Wind Ensemble presented a concert that included two premieres. Lansing McLoskey's *OK*

for saxophone quartet wittily "recontextualized" a Charlie Parker solo's 1058 pitches into a striking, meditative sound-world. Jonathan Newman's suave *Concertino*, which recalled French neoclassicism, received a fine performance by flutist Sarah Kruser Ambrose. And, a roaring conclusion was provided by *Kingfishers Catch Fire*, an attractive and energetic piece by the recently ubiquitous John Mackey. The wind writing by all of these composers showed the promise of this growing repertoire.

Friday morning began with another concert of composer-provided performers. Marilyn Shrude's *Lacrimosa* for alto saxophone and piano opened the program with a tone that was mournful and emotionally complex, and Dohi Moon's [*bi:guni chum*] drew unique sonic effects from a combination of three cellos. Following this concert was a full program by GSU faculty clarinetist Kenneth Long, who also deserves applause for the incredible variety of his program. Two of the pieces were solo, two included piano, and one featured the GSU Percussion Ensemble in the accompanying role. The moods were similarly disparate. John Bilotta's *Heart's Desire* wove Irish folk songs together into a work that felt homespun and honest. Craig Weston's *Still on the Antipodes*, which included the percussion group and piano, featured numerous subtle colors and touches as well as large gestures. Perhaps the best vehicle for Long's playing, however, was Paul Osterfield's *Six Vignettes*. The generic title belies the pieces' quirky and memorable character, and throughout, Osterfield tactfully utilized many clarinet techniques in the service of the movements' individual moods. Friday afternoon's concert again featured various performers. Dorothy Hindman's *Tapping the Furnace* was particularly memorable, using cymbals, coins and narration to recount a story about furnace workers in Alabama. Percussionist Scott

Deal performed the piece with enthralling conviction. This concert was also notable for its inclusion of the conference's only vocal work, part of a song cycle called *Songs of Existence* by Brian Bevelander. One wonders whether the submitted entries on the whole were so slanted away from vocal music. It recalls a point made more than once during the week by George Tsontakis: "Americans don't listen to music, they listen to song." I've been asking myself since whether this insight is accurate, and if so, whether composers are unwisely ignoring it.

Friday evening featured a banquet, with the keynote address provided by Tsontakis. As throughout the week, our guest composer proved himself here to be an eloquent spokesman for the field, an open-minded advocate who likes to remind others that "my colleagues are writing up a storm." It is refreshing to know that on the highest levels of the profession there are individuals who clearly appreciate the complexity of the many issues facing composers.

Saturday's first two concerts again exhibited the variety to which those in attendance had become accustomed. Leonard Mark Lewis' *As In Stained Light* showed off some pop-influenced piano writing, Robert Fleisher's *Secrets* made a more traditionally modernistic impression, and Alexander Sigman's *Reflects/Reflexions/Implosions* for solo alto sax blended a Ferneyhoughian aesthetic with scientific inspirations that recalled Varese. Also notable were Kari Henrik Juusela's colorful *Dream Forests*, which contrasted cloudy, soundscape sections with running notes and energetic rhythms, and Zack Browning's *Execution 88*, which brought a jazzlike energy to the familiar genre of modernistic piano music.

George Tsontakis presented a master class that afternoon for GSU composition students, and aside from offering his own insights, he consistently showed a concern for opening the floor and involving everyone in the proceedings. We all benefited from the discussion that resulted, and Tsontakis impressed with his ability to perceive the underlying issues in the students' music and ask the right questions.

GSU's terrific Percussion Ensemble took the stage Saturday afternoon, showcasing another growing repertory that has been a playground for recent composers. Christopher Mont's performance of Jonathan McNair's *Sonata for Solo Percussion* displayed a promising talent, and the piece pleased with subtle sonic connections and carefully planned gestures. Scott Deal and GSU faculty percussionist Stuart Gerber joined forces for two duets, Amelia Kaplan's *Beat it with a Stick* and Marc Satterwhite's *Nazca Lines*. Seeing these two excellent performers working together was a joy in itself, and the composers provided countless inventive ideas. It's an interesting commentary on the state of percussion music that the final piece on the concert, Brandon Hendrix' *Bahrah*, was the first to include anything approximating a real, old-fashioned groove. Depending on one's perspective, this apparent trend away from repeating rhythmic figures could be viewed as a positive or negative development for percussion music, but at the very least, we can clearly say that composers are approaching this genre with great freedom and personal license.

I've mentioned much excellent and memorable music, but the real peaches of the week were the concerts on Friday and Saturday evenings. The former featured largely performers from the Atlanta-based new music group Bent Frequency. The works included Tsontakis' *Seven Knickknacks for Violin and Viola*, Kyle Kindred's piano trio *Inundación*, and Carl Schimmel's *rite.apotheosis*, all of which brought together concerns for color, rhythmic energy, and motion. Mei-Fang Lin's *L'Image reconstituée* similarly wore a modernistic aesthetic tempered by a certain playfulness that made it instantly appealing. Lin also deserves commendation for the perfectly balanced pacing of her four movements. Perhaps most exciting on Friday evening, though, were the two premieres by the winners of last year's

SCI/ASCAP Student Commission Contest. Carolyn O'Brien's *Formicary* and Maxwell Dulaney's *Eastern Limb* both demonstrated exciting young talents. Dulaney's piece contained perhaps the greatest surprise moment of any work on the conference: after an initial section of tense music and dense interaction between the seven players, the texture suddenly opened up to a beautiful, nocturnal soundscape that was tuned with brilliant senses of pacing and space. I was reminded of the classic advice in jazz improvisation, to constantly ask oneself if what one is playing constitutes an improvement on silence. When I mentioned my enjoyment of this section to Dulaney after the concert, he responded that he wanted to "make everyone hang out for a while." In this case, the approach worked perfectly, leaving the audience leaning forward in our chairs with a keen sense of where we were and what we were listening to.

Saturday night's concert was similarly a billboard for the many fantastic new music players who appear to be hanging around in Atlanta. Brian Baxter's *People Movement* opened the concert with a tasteful and concise burst of rhythm, and Orlando Jacinto Garcia's *olas de humanidad*, by contrast, gave the audience a quiet sound piece with little sense of traditional progression. The combination of extremely soft piano strumming over muted violin harmonics was gorgeous sonically, and Garcia connected the episodes and images with the utmost taste. Kyong Mee Choi's *A Slight Uncertainty Is Attractive*, for flute and electronics, followed with an astounding achievement in spatialization. The sounds strongly suggested visual images—not surprisingly, since Choi is also a painter—and the concentration of musical information across the texture was always pitch-perfect. The concert continued with Nickitas Demos' *Akathist*, which provided unexpected doses of wit and dance in an almost startling contrast with much of what we'd heard over the previous days. And to close, there was another attractive and strongly constructed piece by George Tsontakis, his Piano Quartet no. 3.

Thanks are owed to Nick Demos and the students, faculty, and staff at Georgia State. I was constantly impressed with the effort and organization these individuals put forth to make the week a success. The many performers featured, including those from GSU, the Atlanta area, and around the country, also deserve a special mention.

The conference was tiring. I'm sure that everyone in attendance would agree. It was so much music to take in, so many different approaches to digest. But aesthetic pluralism is, after all, inherently a challenge on us as composers, performers, and listeners. As Molly Ivins put it, "The thing about democracy, beloveds, is that it is not neat, orderly, or quiet. It requires a certain relish for confusion." Pluralism may be tiring, may be difficult to understand in sum, may be occasionally off-putting, but you know what? I'll take it. Especially if it means I get to sometimes come across musical gems like the ones I heard in Atlanta. We find ourselves situated today in a perhaps unparalleled atmosphere of artistic freedom, and I was thrilled to sit and listen in a room full of composers who are actively taking advantage of it. So cheers, everyone. Keep on writing, and hopefully I'll see you at the next conference.



Theory or Counterpoint: What Comes First?

edited by Benjamin Williams

DMA, Ohio State University

This discussion took place on the [scimembers] mailing list March 12-15, 2008.

Question:

Bob Wilson:

At this school, like most I have researched, four semesters of theory are required before enrolling in a course in counterpoint. After a semester and a half of theory and composition, however, it seems to make more sense to study them together. Music composition is more applying good counterpoint to an existing melody than following some theoretical methodology.

It appears to me that rather than leading the way, music theory simply organizes and documents existing developments, counterpoint, and voice leading. Simply put, theory is the horse, not the cart, so why in university and college music programs is the cart put before the horse? It makes more sense, to me at least, to teach them both at the same time.

bobwilson@kc.rr.com

Responses:

Clarifying the Issue...

Paul SanGregory:

It seems important to distinguish between the terms *theory*, *harmony* and *counterpoint*. There are *theories* about music that really are "theoretical" as in "not proven or commonly accepted". These are theories that try to explain music, but *do not* try to teach music. Then there is the "*theory of harmony*", which is actually a set of documented guidelines on how composers of the common practice era dealt with matters of vertical sonorities. These guidelines are meant to teach the "language" of common practice music. In this sense, isn't counterpoint part of theory too?

So the discussion here probably should really be focusing on, "Do we teach *harmony* or counterpoint first?"
paul.sansan@msa.hinet.net

Keith Murphy:

Part of the reason 2-voice counterpoint tends to be taught after 4-voice harmony has to do with the histories of American collegiate music curricula: while counterpoint at many schools was once a separate class required for all students, these days they are more likely offered as an elective, if at all.

The reason for counterpoint dropping from the curriculum probably has a lot to do with the recent need to make space in the curriculum for new areas of

study. Theorists had to make a choice as to which topics to keep, and at most institutions they decided to continue the already strong focus on harmony, probably because they thought it was the most practical analytical knowledge for instrumentalists and vocalists who would spend most of their time practicing repertoire from the late baroque through the 19th century.

keith.murphy@aya.yale.edu

Jack DW Ballard, Jr.:

This has been going on for some time. Don't forget the lovely fight between Marpurg and Kirnberger over which comes first: the harmony or the melodies (short version).

jballard@malone.edu

Harmony First...

Paul Siskind:

Students typically come to our programs with prior listening and performing experience mostly in tonal harmonic styles, rather than pre-harmonic contrapuntal styles. It thus makes more sense to begin with the musical styles and syntax with which they are already familiar.

Most of the music that modern musicians interact with was composed from a primarily harmonic conception, not a contrapuntal conception. Therefore, understanding the concepts of harmony first offers more immediate practical connections for modern musicians.

Starting *theory* with *harmony* does not totally ignore any understanding of counterpoint. *Harmony* is typically taught in a way that encompasses two main aspects: 1) understanding the normative syntax of chord progressions; and 2) understanding voice-leading within the chord progressions. Voice-leading is basically the application of contrapuntal principles within a harmonic framework.

siskinpa@postdam.edu

David S. Lefkowitz:

You have to ask, "Who are taking the classes being offered?" For a general music education curriculum you have to focus on the most important elements which, I believe, center on functional harmony.

That said, any department that offers counterpoint classes should consider making those classes available to the students at an appropriate point in their music education.

lefko@ucla.edu

Zae Munn:

Four-part harmony links up quite directly with what most of my students experience as music—homophonic textures, most based on 3- or 4-part voice leading principles, the music they study

in their lessons and perform in their ensembles.

The homophonic tradition is quite present in today's popular music. Many fundamentals texts end with a chapter or two on writing accompaniment patterns based on voice leading manipulations and figurations of basic progressions with triads and dominant 7ths.

It is important also to consider the likelihood that music systems say something about the culture they inhabit. A music that strives continuously to balance independence and cooperation within a deeply hierarchical pitch system does tell us something about the culture it comes from. Much of this cultural feedback comes from experience with the "intensity" of voice leading, as opposed to rhythmic, metric, or timbral intensity. The study of voice leading is a way to unlock that earlier cultural experience and its values.

zmunnn@comcast.net

Counterpoint First...

Conrad Kehn:

It is hard to find a text that supports the teaching of species counterpoint as part of the undergrad theory sequence. This year we switched from Kostka and Payne to Laitz. It includes species right after rudiments.

Music theory is actually music history. We are teaching the theoretical practices of historical periods. We should start with single line music, move to consonant 2-voice writing, add dissonance, and then start working with 4-part settings.

ckehn@du.edu

Elliott Miles McKinley:

Four part harmony is, in essence, four-part counterpoint. Chords are a result of this counterpoint. Thus, the study of counterpoint should precede the study of harmony, which would provide much better insight to the nature of harmony and the art of good voice-leading (something that Schoenberg writes about in *Theory of Harmony*).

e_miles_mckinley@yahoo.com

Hermes Camacho:

It seems best to study 16th-century counterpoint *first*, since it doesn't concern the student with chords' vertical realizations as much and focuses primarily on proper voice-leading. I've found that in students' papers I've graded, the voice-leading is exceedingly poor since they seem to be more focused on the vertical realizations of voices chord-by-chord rather than as a whole melodic line. If you teach students first how to manipulate the voices against each other properly, there's *less* to teach when formal harmony is introduced.

Mozart, Schubert, and Beethoven studied counterpoint first; so, why shouldn't students do the same?
hermes.camacho@gmail.com

Matthew Saunders:

I was inspired by my experience as a TA using the Clendinning-Marvin text, which includes two chapters of not-quite-Fux counterpoint as soon as students learn intervals.

Pedagogically, it gets students thinking about interactions between voices just like it always has (Mozart, Haydn, et al.) When we get to SATB writing, students are already trained to think that way.

It's a practical thing to do that lets students write music that is pretty cool. They are generally at an age where they just *ache* to be expressive—they want to pretend to be Beethoven or Liszt, so let them do what those guys did to learn to about music. If we hook them early, we might be able to win them over.
two2twain@hotmail.com

Jack DW Ballard, Jr.:

Chorale exercises might be compared to learning to drive with a stick, before ever getting in a car. You're throwing in harmonic principles and learning the counterpoint at the same time.
jballard@malone.edu

Both...

Paul SanGregory:

If your goal is to have students understand counterpoint from a 16th-century perspective you don't need to teach them harmony first. In fact, it may be better to not teach them harmony first. But, if your goal is to help students most quickly and efficiently learn how to use functional harmony, then harmony class is still a great thing.

Bach spent years practicing all of the "rules" of harmony via his counterpoint. Of course, his understanding of all of this was far superior to that of students who only learn such rules in 2-4 semesters of harmony class. And, there really is no need for them to compose like J.S. Bach.

From my perspective, "harmony" is counterpoint and counterpoint writes harmony. They are the same.
paul.sansan@msa.hinet.net

Matthew H. Fields:

The vast majority come to college today immersed in commercial music that is written with an indifference towards voice-leading. Whether we approach music first from a vertical or horizontal perspective is a relatively minor distinction, as both approaches are utter news to most students.
composer@matthewfields.com

What about the Students...

Aleks Sternfeld-Dunn:

What's the point in teaching voice leading at all? Most students that we teach theory to are performance and mus. ed. students. Our goal should be to teach students how to analyze music and apply that analysis to the music they are making. In the long run, how many performers need to remember that a chord seventh goes down, or that the \flat 2 of a Neapolitan six go to leading tone? Not nearly as many who need to be able to trace a micro- and macro-structure of a piece.
alekssd@yahoo.com

Jesse Ayers:

Rather than roll our eyes or look down our noses when we hear students in the hallways saying things like, "What's the point of theory anyway?" we might do better to ask ourselves why they aren't making a connection between what we're teaching and what they do in the practice room and in ensembles.
jesse.ayers@sbcglobal.net

Kyle Beckham:

It is difficult to design a curriculum that places an appropriate amount of time on any given compositional or analytical methodology. Electives allow us to spend more time on our individualized interests. The best thing to remember as a composition student is that you aren't limited to one methodology or another.
angelrho@hotmail.com

Greg Robin:

I think the question that some are mistakenly asking is "What is best for the students interest/area?" Universities are not technical colleges. The point of a University degree is to create intelligent well-rounded students. If all you want to do is play, take lessons from a great teacher. A university's purpose is to give knowledge that a student turns in to wisdom. The university should not be a job placement agency. We learn what is needed to be an intelligent "classical" musician. It is a student's job to assimilate it to their daily lives. If we do not continue educating what we know should be taught at a collegiate level, we will all become job counselors telling students what the hot job commodity of the day is.
robin109@bama.ua.edu

Joseph Di Ponio

How does this relate to what the students are learning in their music history courses? Harmony did not simply happen. Zarlino deals with the basic rules of harmony in his treatise (although he understood harmony from the standpoint of counterpoint). And

what of Palestrina and Monteverdi? One of the obligations of the artist is to make use of, and perhaps contradict, all that has come before, and the obligation of the teacher is to expose the student to as much as possible.
joseph.diponio@gmail.com

What Next?...

Kyle Beckham:

Why not teach strict counterpoint for the first 1 1/2 semesters for entering composition students in a private lesson format and transition into "normal" composition at the end of the year? Some schools won't even allow students to declare a composition major until their junior year anyway, so this would only improve their chances.
angelrho@hotmail.com

John White:

The relationships of theory and counterpoint to musicianship are complex enough that I have written a short book on the subject, *Guidelines for College Teaching of Music Theory*, Second Edition, by John D. White; The Scarecrow Press, Inc; New York and London, 2002, 227 pages.
jwhite48@earthlink.net

Jim Sain

Counterpoint is a composerly craft and best taught by composers (and not theorist that compose). That said, there are only so many classes a composition faculty can teach and, in this time of economic intrenchment, we're not likely to see another composer line added to our faculty any time soon. In the academy we must not only set lofty goals but also deal with reality. But, that's another story.
jsain@ufl.edu

Concluding Thoughts:

Bob Wilson:

Clearly, the only effective way to determine which pedagogical ideas are the most effective would be to examine/test matriculated students several years after they have graduated. That would be an interesting dissertation topic for a DMA candidate, the discussion of which is clearly for an entirely different thread.

If the goal is to produce the best educated musicians, and my experience is typical, then shouldn't various curriculums be open to modification to achieve that goal?
bobwilson@kc.rr.com

For more information, including how to join and participate in the listserv go to:

<http://www.societyofcomposers.org/data/publications/listserv/listserv.html>

SCItings

Member News and Activities



David Heuser

In 2007 **David Heuser's** orchestral work *A Screaming Comes Across the Sky* won the Columbia Orchestra's American Composer Competition; the Maryland-based orchestra performed the piece in June.

He also received a Composer Assistance Program grant from the American Music Center for preparation of performance materials for the premiere of *Something Miraculous Burns*, commissioned by the San Antonio Symphony and premiered in November 2007. The work was hailed as "...luminously gloomy...intense, deeply felt music...masterful in harmony and orchestral color" by San Antonio Express-News senior critic Mike Greenberg. The same critic said of *Thin Green Traces*, a twenty minute work for violin and piano premiered by the SOLI Chamber Ensemble in December, that it was "darkly expressive music...tautly disciplined and lean."

Also in 2007 Heuser received an Artist Foundation of San Antonio grant for a saxophone quartet piece which he will write in 2008 for a consortium of eleven saxophone quartets from around the country.

Currently Heuser is writing an orchestral work called *Three Lopsided Dances* for the Texas Music Festival which will premiere the piece in Houston in June 2008.

Dr. William P. Alexander has recently been honored with a plethora of commissions, performances, and special recognition. His *Symphony No. 2* was

commissioned by the York Symphony on the occasion of its 75th anniversary, and it will be performed on April 26 2008.

The Concert Band of Northwest Pennsylvania commissioned him to write two works, *Claremont* and *Episodes*, both of which will be conducted by John Fleming in their respective premieres in April and June, 2008.

Saxophonist Patrick Jones commissioned *A Neobaroque Suite* for alto saxophone and piano, which will be presented at the International Saxophone Congress in June, 2008.

Many other works will be played by The Erie Philharmonic as part of the retrospective leading up to and beyond the composer's 80th birthday:

- "Three Visions" after poetry by Brett Rutherford, April 7, 2005, Hugh Keelan, conductor
- "From the Sacred Harp", November 16, 2005, Hugh Keelan, conductor
- *Suite No. 1* for Orchestra, April 26, 2005, Hugh Keelan, conductor
- "Todesblumen", November 15, 2006, Peter Stafford Wilson, conductor
- "Ashes and Equinox", February 7, 2007, Peter Stafford Wilson, conductor
- "Two Portraits", April 25, 2007, Bruce Morton Wright, conductor
- *Concerto for Saxophone and Orchestra*, Patrick Jones, saxophone, Victor Yampolsky, conductor
- "quietude and repartee" April 23, 2008, Daniel Meyer, conductor
- *Concerto for Flute and Saxophone*, November 12, 2008, Daniel Meyer, conductor

He was also recently honored with an ASCAP Plus Award in 2007.

Most significantly, the new music building on the campus of Edinboro University of Pennsylvania is now complete and is being used by the Music Department. The building is known as the Dr. William P. Alexander Music Center, in honor of the composer's 46 years of association with the university, where he is now emeritus professor of music history and composition.

Dr. Dorothy Hindman's work for guitar solo, *Needlepoint*, was released on the Musings compact disc released by the Society of Composers, Inc. series on Capstone Records, and her work *Seconds* for electronics is featured on Vox Novus' 2004-05 60x60 double disc.

Selected recent performances include: two performances of Hindman's *Incarnation* for choir by the Coro Odyssea in Portugal in July; five performances of Hindman's *Streaming* for orchestra by the Alabama Symphony Orchestra in September; a performance of Hindman's guitar quartet *Taut* by the Corona Guitar Kvartet on the "Nuovi Spazi Musicale" Festival in Rome, Italy in October; the premiere of Hindman's *Tapping the Furnace* for speaking percussion solo by Stuart Gerber on a Bent Frequency concert in Atlanta, GA; two performances of Hindman's *Needlepoint* for guitar solo by Paul Bowman in San Diego and Birmingham; and a performance of Hindman's *Beyond the Cloud of Unknowing* for marimba solo, performed by Scott Deal at the College Music Society National Conference in Salt Lake City, Utah, in November.



Dr. Dorothy Hindman

Daniel Adams' Concerto for Marimba and Percussion Ensemble was performed in Flushing, New York by the Aaron Copland School of Music Percussion Ensemble, conducted by Michael Lipsey on November 16, 2007. The concert was part of the New Music Festival jointly-sponsored by the Society of Composers, Inc. and the Long Island Composers Alliance.

Adams' *Two Antiphonal Portraits* for percussion ensemble was performed in Tampa, Florida by the University of South Florida Percussion Ensemble, conducted by Robert McCormick on November 19, and in Baton Rouge by Hamiruge (the Louisiana State University Percussion Ensemble) conducted by Emory Blake on November 28.

Daniel Adams is the author of an article entitled "2007 PAS Composition Winners" published in the October 2007 issue of *Percussive Notes*, the journal of the Percussive Arts Society. Adams also received an Award from the American Society of Composers, Authors, and Publishers for his music composition activities in 2006-2007.



Daniel Adams

Donald Yu's work has been extensively performed throughout the US and overseas.

On February 14 2007, his *Mystical Aria* for organ and *Anthem: Our Father* for chorus were premiered at the Memorial Church of Harvard University in U.S.A. Cambridge, Massachusetts, with Carson Cooman conducting and playing the organ.

On March 25, 27 and 28 2007, Yu's newly commissioned *Twelve Preludes* for organ was premiered by Carson Cooman, at the San Francisco El Grande in Ciudad de Mexico during the 'Viaje de Mexico.'

On April 1 2007, *Reflections for Trombone Choir* was premiered by the Ithaca Trombone Troupe, conducted by Erik Kibelsbeck at the 18th Annual Fruehling Posaunen Concert at Pennsylvania State University's Esber Recital Hall. The piece was subsequently played by the same group on April 2, at Elmira College's Gibson Theatre in Elmira, New York.

Yu's *Frankenstein* for organ and cello was premiered on May 30 2007 at the Adolphus Busch Hall of Harvard University in U.S.A. Cambridge, Massachusetts. Performing were Tomas Dunn, cello, Carson Cooman, organ.

On July 31 2007, Yu's *Sonata for oboe solo 'Echo I'* was performed at the Com-

munity Culture Centre's Auditorium in Waltham, Massachusetts, performed by oboist Regina Wilkins.

On September 11 2007, *Recalling from Dreams* for trumpet and piano was premiered in the Faculty Recital at the University of Northern Iowa's Gallagher-Bluedorn Performing Arts Center's Davis Hall in U.S.A. Iowa. Performing were professor Randy Grabowski on trumpet and Sean Botkin on piano.

Donald Yu has also had several performances outside the US.

On July 20 2007, *Etude for Piano 'Birds' Uncertainty for Piano, Fantasy on 'The Lady of Shalott' for Piano, Sonata No.4 'Chaos' for Piano, Hell and Heaven for piano, Autumn Elegy II* for violin, piano and guitar, and *Explosion* for piano were all performed at the 2007 soundSCAPE's "Special Presentation" in Sala Beato Angelico in Cortona Italy. All pieces were performed by the composer.

On May 2 2007, *Romantic Light Piece No. 2* for cello and piano was performed in England, Canterbury Christ Church University's St. Gregory Centre for music. The cello part was performed by Max Cheung; the piano part was performed by Kim Burwell.

On May 27 2007, *Explosion* for piano, *Two Chinese Poems for Baritone and piano* were premiered at the HKBU Honours Project Composition Concert in the Academy Community Hall, performed by Man-Ching Yu. On August 7, 2007, *Explosion* for piano was also performed by Man-Ching Yu at the Kleine Studio at the 2007 International Summer Academy of Mozarteum in Salzburg, Austria.

On November 2nd, *Incidental Music* for a chinese poetic drama 'Phoenix' was



Donald Yu

performed at the Wei Hing Theatre of the City University of Hong Kong, piano performed by the composer.

Two new works are scheduled for premiers on April 27, 2008 at the Atonement Lutheran Church in Syracuse, New York: the Concert Overture '*Hong Kong Night Scene Sketch*' and the Symphonic Sketch '*Nocturne*.' Both pieces will be performed by the Onondaga Civic Symphony Orchestra, conducted by Erik Kibelsbeck.



Anthony Cornicello

Anthony Cornicello's "*I'll Have an Electric Mahabharata, Please*" is scheduled for a performance on the 2008 SEAMUS Festival in Salt Lake City, UT. The 2003 work, written for violoncello and live electronics will be performed by Madeleine Shapiro.

In 2007, Cornicello received a commission for *Syncretic Resonances*, for two clarinets and electronics. The piece will have its premiere on the ClarinetFest in Kansas City in July, 2008, and will be performed by F. Gerard Errante and D Gause, the commissioners of the work.

Forthcoming works include *The Interactive Pianist* (for piano and electronics), written for Kathy Supové, and a song cycle with texts from Lawrence Ferlinghetti's *A Coney Island of the Mind*.



TECH CORNER

Technology How-To

by **Anthony Cornicello**

Associate Professor, Eastern Connecticut State University

For some of us, the diagram below is second nature. Many composers are quite familiar with Max/MSP - well enough to have an idea of what the 'patch' below will sound like. Yet, there are some members of SCI for whom electronics is a mystery, a confusing torrent of arcane buzzwords and cryptic symbology.

The technologically-inclined musician is no longer an oddity. In days past, there were composers and computer technicians; they seemingly spoke different languages, and so their paths almost never crossed. There was the occasional individual who dared to bridge both worlds. Today, most composers under the age of 45 are well-versed in electronic music, and computers have become an integral part of our lives, for better or worse. This, of

course, is not news to many of you. I'm sure that most of our readership will have a good level of proficiency in one program or another. For some, it will be Csound, others will know OpenMusic, and readers will be happy with Finale.

My idea for this column is to answer questions posed by the members of SCI. *What's the best keyboard for inputting music on my computer? What printer should I use? Is this interface overkill for my purposes?* I'm sure many of you have burning questions you'd like to see answered. And, I'll be certain to post some of the questions online, to see how some of you respond.

For my first column, I'd like to issue a call for a general survey. What notation software do you use, and why? Certainly, a loaded question! Did you gravitate towards the software because a teacher was using it? Were you attracted to certain features? Do you constantly make a wish list for the upgrades you'd like to see? Let's see where this takes us! Send your responses to me at cornicelloa@easternct.edu.

I should mention that this is the 20th anniversary of my first purchase of a computer. Not quite as romantic as your first kiss, but writing a column like this certainly makes me think about how things have changed. My first computer was a 286, and out of the box it did pretty much nothing. Until I installed programs, all the computer could do was blink at the C:> prompt. And, when the programs were finally up and running they were incredibly slow, with crude interfaces that tended to hinder rather than inspire. Times have changed indeed, as I routinely use more than ten programs each day (most with 'real time' response), with many more used on a less than regular basis. Keeping up with all the software (and hardware) can be a real challenge, but well worth the effort.

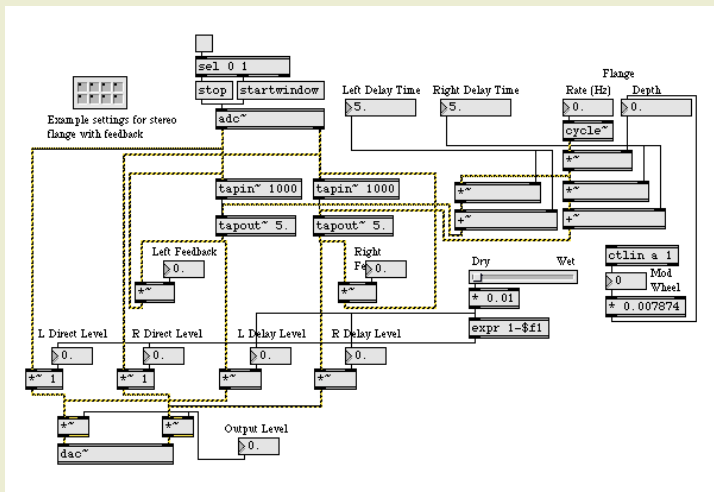

S C I R E S O U R C E S (C O N T I N U E D)

iSCI: The Composers Perspective

The Internet Journal of the
Society of Composers, Inc.

SCI has launched a new on-line journal for the publication of music scholarship by composers and for composers, edited by Jason Bahr and Craig Weston. We hope to present the composer's unique point of view through an exciting mix of theory and analysis, "shop talk," pedagogy, and practice. This list is not inclusive: this is the place for colloquy on everything that matters to composers. Contributors are encouraged to exploit the multi-media possibilities of on-line publication.

Jason Bahr, Mississippi State University,
bahrline@yahoo.com

Call for Submissions (no deadline)

Please send submissions electronically to Craig Weston at cweston@ksu.edu. Also include an abstract of no more than 300 words describing your work. Abstracts should be submitted as an .rtf or .pdf file attached to an email. Works may be submitted as traditional papers, multi-media presentation, podcasts or other formats. Past presentations from SCI Conferences are eligible. Inquiries are welcome - please address them to both editors.

Craig Weston, Kansas State University,
cweston@ksu.edu

MEMBERSHIP INFORMATION

For complete details, please visit <http://www.societyofcomposers.org/data/organization/membership.html>

FULL MEMBERSHIP (\$55/year): Eligible to submit scores to the National Conferences, regional conferences, SCI Recording Series, SCI Journal of Music Scores. Access to the SCI Newsletter in electronic form. Optional subscription to [scimembers], the SCI listserv and all other SCI publications. Eligible to vote on Society Matters and in elections for the National Council.

JOINT MEMBERSHIP (\$75/year): Same benefits as full members

SENIOR MEMBERSHIP (\$27.50/year): Open to those 65 years of age or older, or retired. Same benefits as full members.

ASSOCIATE MEMBERSHIP (\$27.50/year): Open to performers and other interested professionals. Receives the SCI Newsletter in electronic form and can participate in national and regional conferences.

STUDENT MEMBERSHIP (\$27.50/year): Eligible to submit to national and regional conferences and to vote in society matters. Access to all SCI publications.

STUDENT CHAPTER MEMBERSHIP (\$17.50/year): Same benefits as student members, but only available on campuses having Student Chapters.

INSTITUTIONAL MEMBERSHIP (\$25/year): Organizations receive hard copy of the SCI Newsletter and other mailings.

LIFETIME MEMBERSHIP (\$1100 or \$120/year for 10 years): Benefits the same as full members, for life.

PUBLICATIONS

Publications include the *SCI Newsletter*, *SCI Recording Series*, *Performers CD Series*, *SCI Journal of Music Scores*, and **SCION** (monthly e-mail listing of announcements and opportunities for composers).

ANNOUNCEMENTS

Announcements of contests, calls for scores, and other solicitation appear in the *SCI Newsletter* and **SCION** as a service to SCI members. While every effort is made to assure the accuracy of these announcements, SCI cannot accept responsibility for errors, misrepresentations, or misinterpretations.

P I X E L P E R F E C T : M E M B E R P H O T O S

Pixel Perfect

Photos of SCI Members



Photo by Gerald Warfield
Richard Brooks and a friend at the Atlanta Aquarium.
(His friend did not attend the National Conference.)



Photo by Tom Wells
Gerald Warfield and Craig Weston confer over iSCI at the Atlanta Conference.